

# Explosion Proof Scale

## AZ-Bseries

**Dry-cell battery powered, easy-to-install,  
with a maximum runtime of 1,000 hours**

- Battery powered for convenient use anywhere (Four D size dry-cell batteries)
- The design for low power consumption helps reduce carbon dioxide emissions
- A large LCD display with back-light (Auto power-off function)



AZ-B60K  
AZ-B150K

AZ-B30K

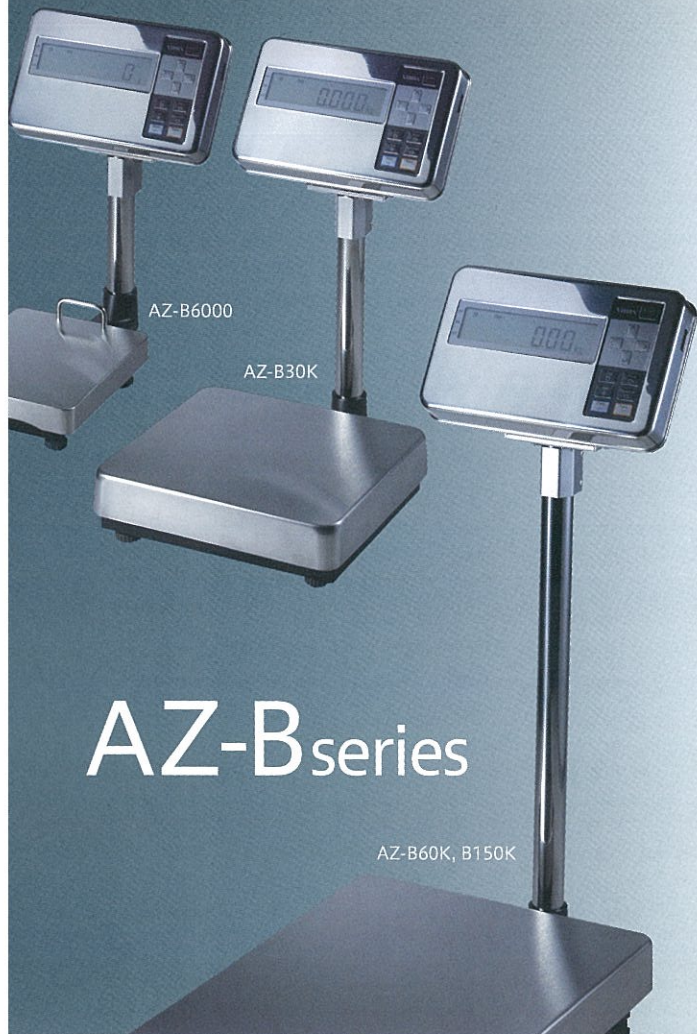

# AZ-B series

AZ-B60K, B150K

## Dry-cell battery operation

About 1,000 hours runtime  
(when using four D size alkaline dry-cell batteries with back-light turned off)  
\* Change batteries only at a non-hazardous area.



## Arrow keys allow for easy operation

The arrow keys located to the right of the display allow the user to select their desired function directly from a variety of options.



## Auto power-off, large LCD display area with back-light

Large LCD (25mm height) with blight back-light make the weighing operation easy and comfortable even in the dark location.

After the system is inactive for a certain amount of time, it automatically shuts down, thus limiting power consumption.



## Easy angle adjustment

You can easily adjust the panel angle to select the panel position most suitable for the application and location.



## Specifications

Model	AZ-B6000	AZ-B30K	AZ-B60K	AZ-B150K	AZ-B450K
Capacity	6000g	30kg	60kg	150kg	450kg
Readability	1g	0.005kg	0.01kg	0.02kg	0.1kg
Pan size	200x250mm	330x310mm	380x530mm		550x700mm
Dimensions(LWH)	294x400x435mm	330x448x540mm	380x669x815mm		Separate type

## Common Specification

- Tare subtraction range : Full weighing range
- Calibration : Manual operation with external weight
- Overload indication : [o-Err] is displayed if weight capacity +9 intervals are exceeded.
- Display : LCD (25mm height) with back-light, seven segments, maximum seven digits
- Temperature/ Humidity : 5°C to 35°C/ 80%RH or less (non-condensing)
- Power source : Four D size alkaline dry-cell batteries (LR20) or four D size manganese dry-cell batteries (R20PU) (operate for 1000 hours when back-light)

## Dimensions (mm)

### AZ-B6000

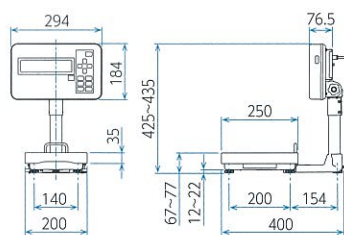

### AZ-B30K

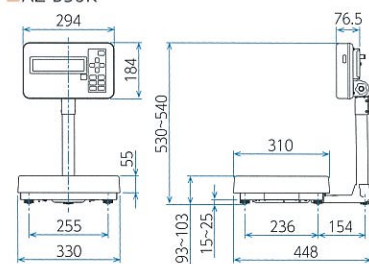

### AZ-B450K

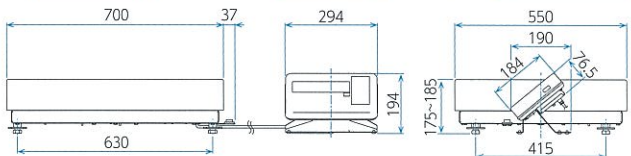

### AZ-B60K, B150K

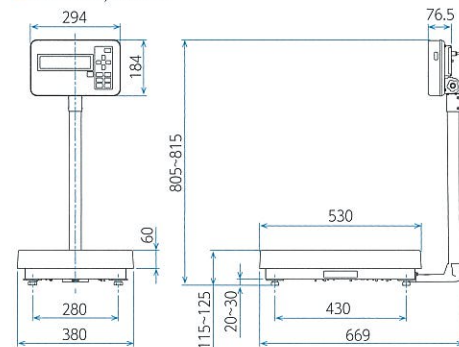

The contents of this catalogue are subject to change due to modifications and/or other reasons.

● Distributed by:

# SHINKO DENSHI CO., LTD.

3-9-11 YUSHIMA, BUNKYO-KU, TOKYO 113-0034

TEL : 81-3-3831-9656 FAX : 81-3-5818-6066

URL <http://www.vibra.co.jp/global>

E-mail [shinko-denshi@vibra.co.jp](mailto:shinko-denshi@vibra.co.jp)



JQA-2834 ISO 14001:2004  
JQA-QMA13875 ER-00130

